

Explosion proof products

**Hidria**

**■ EXPLOSION PROOF PRODUCTS**

---

**Swirl diffusers and variable swirl diffusers**

---

OD-9

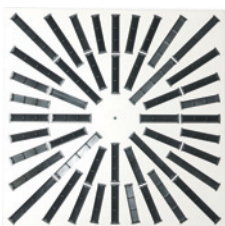

OD-11V/TR

**Overpressure and volume control dampers**

---

JNŽ-6



RŽ-1

**Shut-off dampers and mechanical flow rate controllers**

---

ZL-1



MRP-1



MRP-2

**Non-return dampers**

---

RSK

**Fire dampers**

---

PL-15

**Air handling units Klimair2**

---



# EXPLOSION PROOF PRODUCTS

---

	<b>Page</b>
▶ Swirl diffusers OD-9.....	3
▶ Variable swirl diffusers OD-11V/TR.....	4
▶ Overpressure dampers JNŽ-6.....	5
▶ Volume control dampers RŽ-1 and RŽ-2.....	6
▶ Shut-off dampers ZL-1.....	7
▶ Mechanical flow rate controllers MRP-1 and MRP-2.....	8
▶ Non-return dampers RSK.....	9
▶ Fire dampers PL-15.....	10
▶ Air handling units Klimair2.....	15

---

**The use in potentially explosive atmospheres**  
**Product suitability according to standards**

Product	Standard		
	SIST EN 13463-1: 2001	SIST EN 1127-1:1998	SIST EN 60079-10: 1997
	Non-electric equipment for potentially explosive atmospheres – Part 1: Basics and requirements	Explosive atmospheres – Explosion prevention and protection – Part 1 Basic terms and methodology	Electric devices for explosive gas atmospheres – Part 10: Potentially explosive atmosphere classification (IEC 79-10:1995)
<b>OD-9</b>	✓	✓	
<b>OD-11</b>	✓	✓	
<b>JNŽ-6</b>	✓	✓	
<b>RŽ-1</b>	✓	✓	✓
<b>RŽ-2</b>	✓	✓	✓
<b>ZL-1</b>	✓	✓	✓
<b>RSK</b>	✓	✓	
<b>MRP-1</b>	✓	✓	✓
<b>MRP-2</b>	✓	✓	✓
<b>PL-15</b>	✓	✓	✓

**Product suitability according to requirements**

Product	Requirement		
	Category	Explosive atmosphere zone	Explosion safety level
<b>OD-9</b>	2G	zone 1	IIB
<b>OD-11</b>	2G	zone 1	IIB or IIC
<b>JNŽ-6</b>	2G	zone 1	IIB
<b>RŽ</b>	2G	zone 1	IIB
<b>RŽ (inside Ex)</b>	-/2G	zone 1	IIB
<b>ZL-1</b>	2G	zone 1	IIB
<b>ZL-1 (inside Ex)</b>	-/2G	zone 1	IIB
<b>RSK</b>	2G	zone 1	IIB
<b>MRP-1</b>	2G	zone 1	IIB
<b>MRP-1 (inside Ex)</b>	-/2G	zone 1	IIB
<b>MRP-2</b>	2G	zone 1	IIB
<b>MRP-2 (inside Ex)</b>	-/2G	zone 1	IIB
<b>PL-15</b>	2G	zone 1	IIB
<b>PL-15 (inside Ex)</b>	-/2G	zone 1	IIB

**Explosion proof products**

Products in the Ex range are intended for use in explosive atmospheres. According to the frequency of explosive atmosphere occurrence in the environment where the Ex range product is mounted, this is divided into zones 0, 1, 2 (gases) and zones 20, 21, 22 (dust). In respect to each zone the category of permitted equipment is divided accordingly.

For each Ex range system intended for use in potentially explosive atmospheres, the manufacturer must obtain an ATEX certificate in accordance with the Directive 94/9/EC.

The certification process must be performed by one of the registered institutions in the EU. Within the field of explosion protection in Slovenia, the SIQ is accredited with the Slovenska akreditacija (Slovene accreditation) and the German DAP. A certificate granted by any of the registered institutions is valid in the entire EU area.

Hidria IMP Klima produces II 2G XXXX labelled products, which means that these are to be installed in Zone 1 industrial areas - installation in gas atmospheres where explosive atmosphere occurrence is probable.

We issue a Declaration of Conformity for all our products (also required under 94/9/EC). All products listed in this catalogue (except air conditioning systems that have a technical file deposited) have a type test report made with the SIQ.

**Application of OD-9 in explosion proof version**

Diffuser model OD-9/Ex is an explosion proof diffuser intended for use in potentially explosive areas and does not provide a source of ignition of the explosive atmosphere.

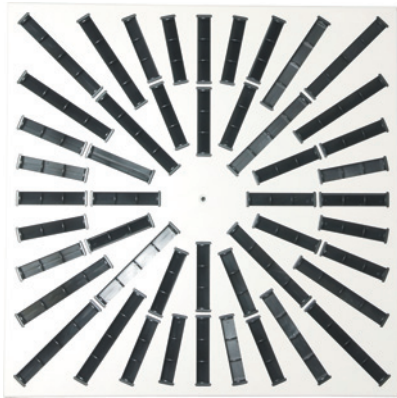

**Ordering key:**

**OD-9 / KK1 / Z / S / M / Ex / 310**

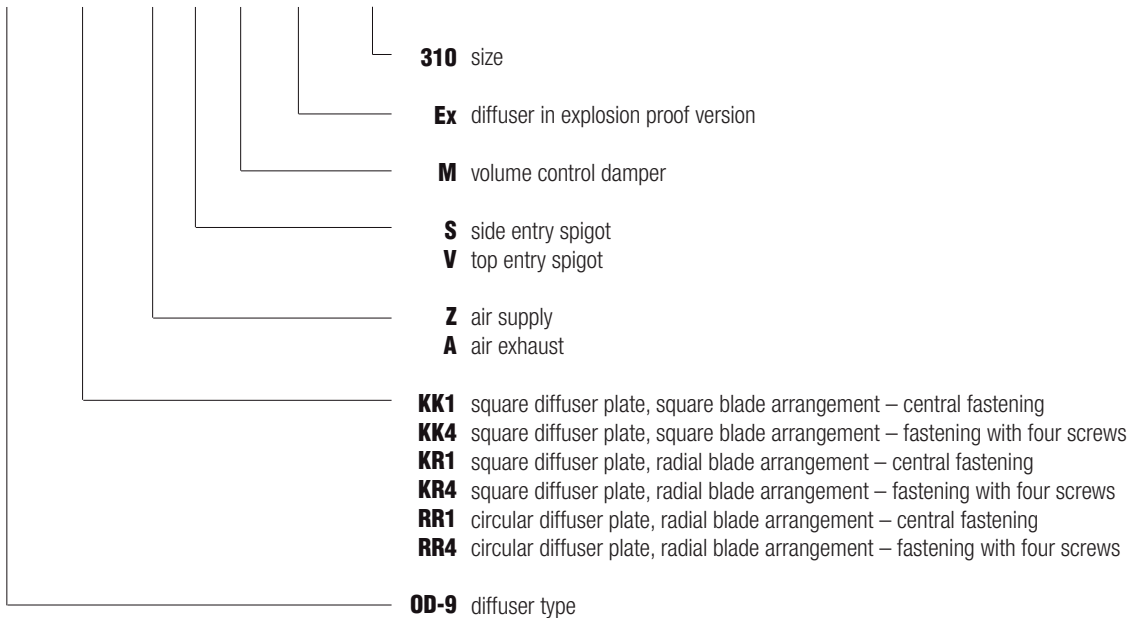



**Application of OD-11V/TR in explosion proof version**

Variable swirl diffuser model OD-11V/TR/Ex is an explosion proof diffuser intended to be installed in potentially explosive areas and does not provide a source of ignition of the explosive atmosphere.

**Ordering key:**

**OD-11 V / TR / P / K / M / Ex / 315**

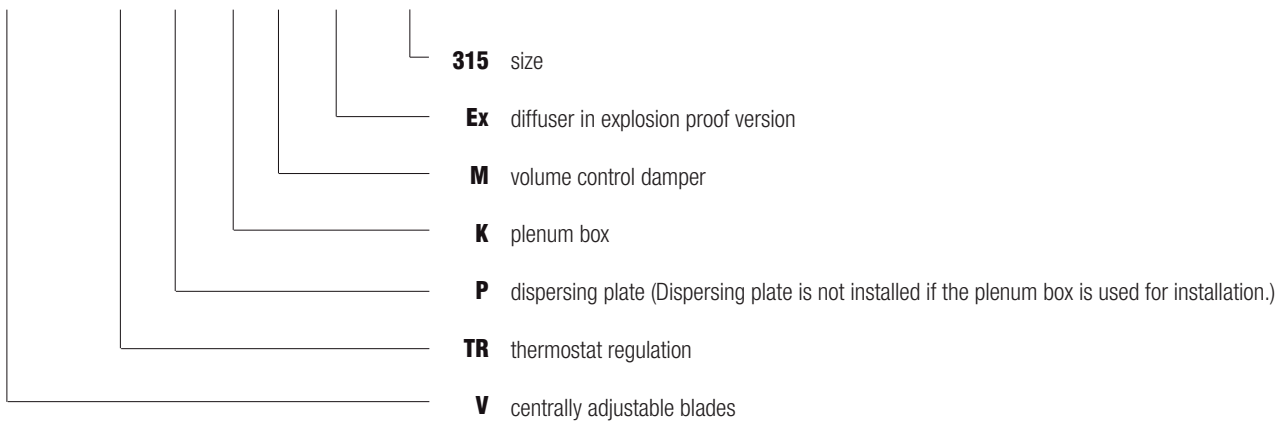



**Application of overpressure dampers JNŽ-6 in explosion proof version**

Types of overpressure dampers in explosion proof version:

- Overpressure dampers JNŽ - 6 with weight
- Overpressure dampers JNŽ - 6
- Overpressure dampers JNŽ - 6 with more blades

Ordering key:

**JNŽ-6/Ex/ with weight / $\Delta p$  BxH**

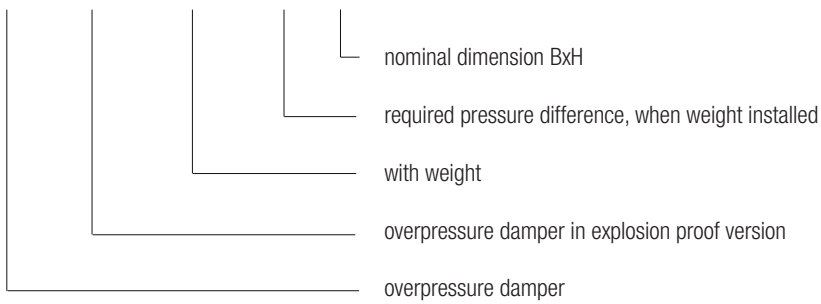



**Application of volume control damper RŽ in explosion proof version**

Volume control dampers type RŽ are designed for airflow and pressure regulation in ventilation ducts and air conditioning units that are built-in in potentially explosive areas of ventilation ducts that transport or are the source of explosive gas mixtures, fumes and aerosols. These dampers can be built in individually or in combination with overpressure or protection louvres. These can be opened or closed manually, with an electromotor or a pneumatic drive.

**Volume control damper types:**

Two basic types:

- RŽ-1
- RŽ-2

By the position of the blades, which enables different options of intake and exhaust of air:

- RŽ-1A (image 2)
- RŽ-1B (image 3)

By Ex protection level:

- only the interior of the volume control damper is Ex grade
- The entire damper composition is Ex grade (the interior and exterior part of the damper)

By drive used for control – opening, closing of the damper:

- electromotor model of a volume control damper,
- pneumatic model of the damper,
- manual model.

**Volume control damper with Ex grade interior**

The volume control damper with the Ex grade interior is the borderline between a potentially explosive area and an explosion-safe area. That is why it is important that the equipment installed in the exterior part of the volume control damper is Ex grade. Its drive can be manual, electromotor or pneumatic cylinder driven.

**Volume control damper with Ex grade interior and exterior**

With the volume control damper that is completely Ex grade, all of the equipment that is fitted in the exterior of the damper is in accordance with the Ex requirements for the area where it is fitted. These dampers are located in areas where the interior and exterior part of the damper is in a potentially explosive area.

**Motor actuators**

**Motor actuators Schischek:**

Code Hidria	Code Schischek
S1	ExMax-5.10
S2	ExMax-15.30
S3	ExMax-5.10-S
S4	ExMax-15.30-S
S5	ExMax-5.10-Y
S6	ExMax-15.30-Y
S7	ExMax-5.10-F
S8	ExMax-15-F
S9	ExMax-5.10-SF
S10	ExMax-15-SF
S11	ExMax-5.10-YF
S12	ExMax-15-YF
S13	ExMax-5.10-BF
S14	ExMax-15-BF

**Motor actuators Belimo:**

Code Hidria	Code Belimo
B7	SM 24A
B8	SM 230A
B9	SM 24A SR
B10	SM 230A SR
B11	GM 24A
B12	GM 230A
B13	GM 24A SR

**Ordering key:**

**RŽ-1A / R / Ex-Z / size**

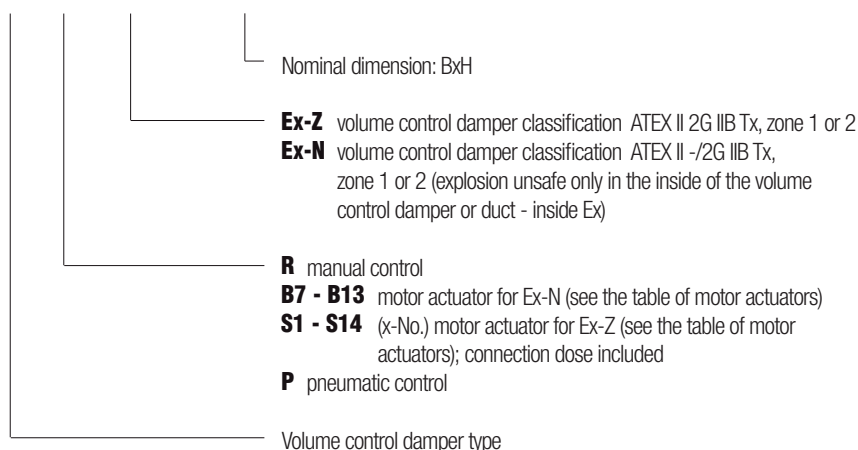

**Application of shut-off dampers ZL-1 in explosion proof version**

Shut-off dampers ZL-1 in Ex grade are used to shut off the intake or exhaust air in the case of ventilation systems that have to provide a high level of cleanliness in a space and are fitted in potentially explosive areas, or mixtures of explosive gases or aerosol are transported in these systems. These dampers are used predominantly in systems with absolute filters. Shut-off dampers ZL-1 in Ex grade are used in ventilation systems with the intent to prevent leakage of explosion hazard gas and dust from a potentially explosive area into an area with no explosion potential. This gives us the opportunity to use equipment in the adjacent area that is not completely Ex grade.

**Shut-off dampers types:**

According to explosion safety degree:

- Only the inside of shut-off damper is made in explosion proof version;
- The entire shut-off damper is made in explosion proof version (inside and outside of the damper).

According to the control type – opening, closing the shut-off damper:

- motor actuator,
- pneumatic control,
- manual control.

According to installation of shut-off damper:

- installation into round duct,
- with “jacob” clamp.

According to the material, the shut-off damper is made of:

- galvanised sheet steel,
- stainless steel.

**Shut-off dampers with Ex grade interior**

Shut-off dampers with Ex grade interiors are at the boundary between an potentially explosive area and an explosion-safe area. This is why the equipment fitted in the exterior part of the shut-off damper is not entirely Ex grade (not necessary). Its drive can be manual, electromotor or pneumatic cylinder driven.

**Shut-off damper with Ex grade interior and exterior**

The shut off damper that is completely Ex grade, has all of the equipment fitted on the exterior part in accordance with the Ex protection and the requirements where the damper will be fitted. Shut-off dampers are located in areas where the interior and exterior parts are in a potentially explosive area.

**Shut-off damper made of galvanised sheet steel**

Shut-off damper is made of galvanised sheet-steel, or some of its parts are galvanised. All the screws are made of galvanised sheet steel.

**Shut-off damper made of stainless sheet steel**

Entire shut-off damper is made of stainless steel sheet including screws. pneumatic cylinder driven.

**Motor actuators**
**Motor actuators Schischek:**

Code Hidria	Code Schischek
S1	ExMax-5.10
S2	ExMax-15.30
S3	ExMax-5.10-S
S4	ExMax-15.30-S
S5	ExMax-5.10-Y
S6	ExMax-15.30-Y
S7	ExMax-5.10-F
S8	ExMax-15-F
S9	ExMax-5.10-SF
S10	ExMax-15-SF
S11	ExMax-5.10-YF
S12	ExMax-15-YF
S13	ExMax-5.10-BF
S14	ExMax-15-BF

**Motor actuators Belimo:**

Code Hidria	Code Belimo
B7	SM 24A
B8	SM 230A
B9	SM 24A SR
B10	SM 230A SR
B11	GM 24A
B12	GM 230A
B13	GM 24A SR

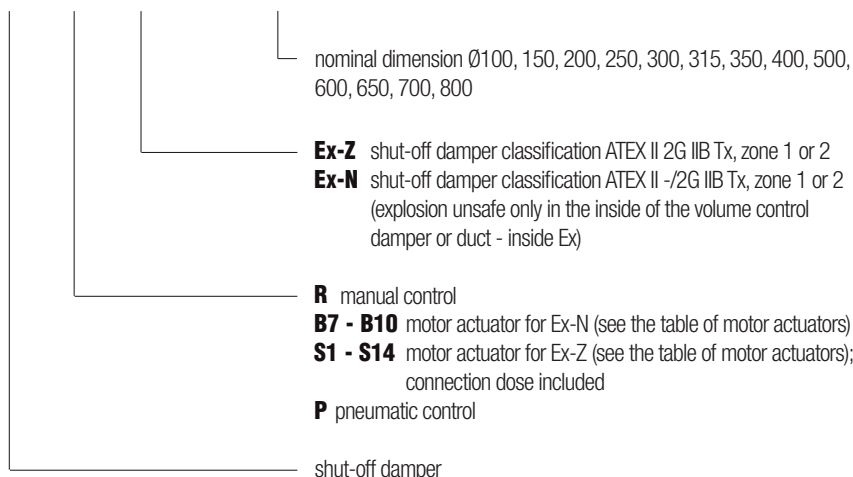
**Ordering key:**
**ZL-1 / R / Ex-Z / size XXX**

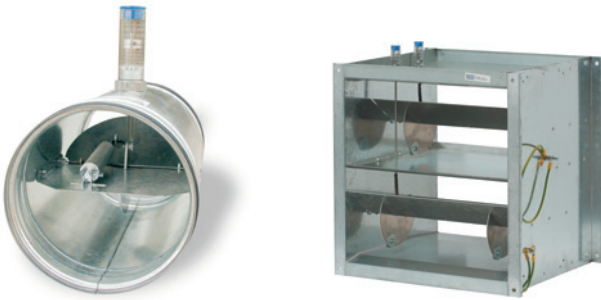

**Application of explosion proof mechanical flow rate controller**

Mechanic flow rate controllers in Ex grade are devices intended to be fitted in potentially explosive areas where mixtures of explosive gases are transported or occur in the ventilation.

**Types of explosion proof flow rate controllers**

According to the control type:

- mechanical control,
- motor actuator,
- pneumatic control.

**Mechanical flow rate controller with manual control  
MRP-1, 2 /Ex**

Mechanical flow rate controllers with fixed adjustment:

- regulation is automatic without additional power source assistance with basic factory settings or user specific settings with the desired levels of airflow volume.
- after the installation, factory settings of airflow can be changed,
- maximum pressure difference in the controller is up to 1000 Pa.

**Mechanical flow rate controller with moto actuator  
MRP-1, 2/Em/Ex/**

Mechanical fow rate controller with motor actuator, with which we can provide two different flow rates;

- Minimal flow  $V_{min}$ .
- Maximal flow  $V_{max}$ .

These controllers offer the possibility of individual dual regime settings within the required minimum and maximum airflow volume in the ventilation duct. Resetting is possible.

**Mechanical flow rate controller with pneumatic control**

MRP-1, 2/Ex/PS-RLP10 F905-AK42PF003

MRP-1, 2/Ex/PS-RLP10 F916-AK42PF003

Mechanical fow rate controller with pneumatic control, with which we can provide two different flow rates.

- Minimal flow  $V_{min}$ .
- Maximal flow  $V_{max}$ .

They can be pre-adjusted

**Motor actuators Schischek:**

Code Hidria	Code Schischek
S1	ExMax-5.10
S2	ExMax-15.30
S3	ExMax-5.10-S
S4	ExMax-15.30-S
S5	ExMax-5.10-Y
S6	ExMax-15.30-Y
S7	ExMax-5.10-F
S8	ExMax-15-F
S9	ExMax-5.10-SF
S10	ExMax-15-SF
S11	ExMax-5.10-YF
S12	ExMax-15-YF
S13	ExMax-5.10-BF
S14	ExMax-15-BF

**Motor actuators Belimo (for Ex-N only)**

Code Hidria	Code Belimo
B7	SM 24A
B8	SM 230A
B9	SM 24A SR
B10	SM 230A SR
B11	GM 24A
B12	GM 230A
B13	GM 24A SR

**Ordering key:**

**MRP-1 / R / Ex-Z /  $Q_{min}$ - $Q_{max}$  / size**

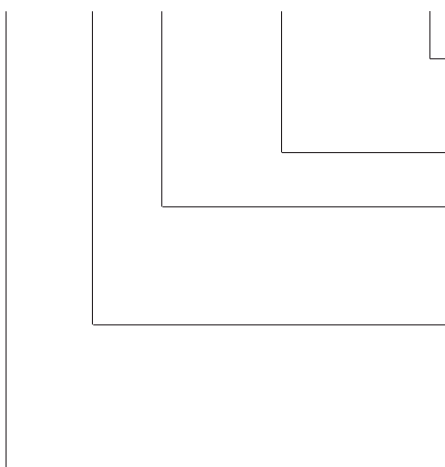

nominal dimension  
Ø80, 100,125, 140, 160, 200, 250, 315, 400

required minimal or maximal flow rate

**Ex-Z** flow rate controller classification ATEX II 2G IIB Tx, zone 1 or 2

**Ex-N** flow rate controller classification ATEX II -/2G IIB Tx, zone 1 or 2 (explosion unsafe only in the inside of flow rate controller or duct - inside Ex)

**R** manual control

**B7-B10** motor actuator for Ex-N (see the table of motor actuators)

**S1-S14** motor actuator for Ex-Z (see the table of motor actuators); connection dose included

**P** pneumatic control

mechanical flow rate controller

**Application of explosion proof non-return damper RSK**

Ex grade non-return damper RSK is an explosion proof damper intended for use in potentially explosive areas and does not represent an ignition source for the explosive atmosphere.

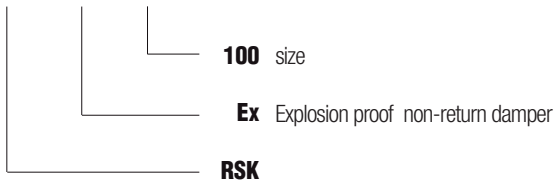
**Ordering key:****RSK / Ex / 100**



PL-15 Ex in ATEX version (with motor actuator E36)

**Application of fire dampers PL-15 in explosion proof version**

**Application:**

Fire dampers prevent fire from spreading in air conditioning and ventilation installations. They are installed at crossings of ventilating ducts through partition walls and ceilings which divide a building into fire compartments. Fire dampers PL-15 are made for rectangular ventilating ducts, with adapters they can be used for installation into round ducts also.

Fire dampers PL-15 are made in accordance with ATEX 94/9/ES and can be used in explosive gas atmospheres.

**Description:**

Fire dampers consist of a two-section housing made of galvanised steel sheet, with the mid section made of a special insulation material, a blade made of a special silicated insulation material, and a thermal release mechanism with the release temperature 72°C (option of higher also). Potential bridging is carried out on all elements of the louvres. Manual handling - fusible link release or electric actuator.

**Fire resistance and classification:**

Fire resistance EI 120-S, tested in accordance with standard EN 1366-2.

**Types according to the release mechanism: for classification ATEX, II 2G IIB Tx, zone 1 or 2:**

- electric actuator (designation E35, E36)

**for classification ATEX II -/2G IIB Tx, zone 1 or 2 (explosion unsafe zone only in the inside of the damper or duct - inside Ex):**

- electric actuator (designations E5, E6, E15, E16)
- manual handling - fusible link release (designation A2)

**Dimensions of PL-15 Ex**

B = from 250 to 1500 mm

H = from 250 to 800 mm

Upon request fire dampers of custom dimensions within the range of standard dimensions can be produced.

Standard damper length PL-15 Ex , L=400 mm.

It is possible to make fire damper dimension 250 x 250 reduced to 150 x 150. On request we can adapt the damper to different specific installation situations.

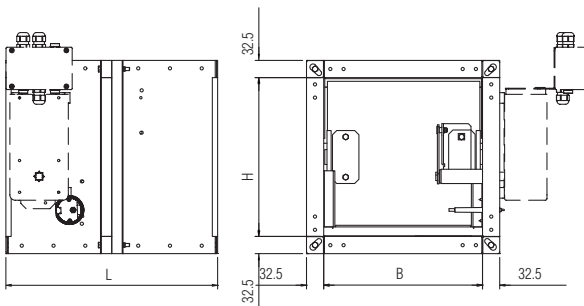

PL-15 Ex- main dimensions

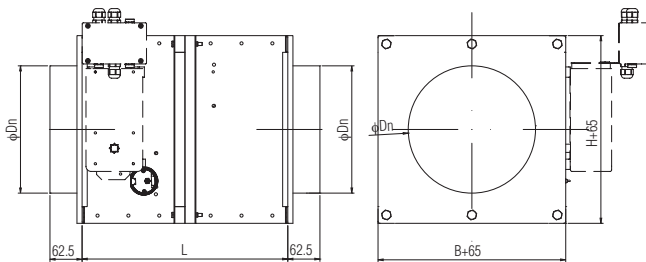

PL-15 Ex- for round duct

**Types for round ducts:**

For connection into round ducts PL-15 Ex with reducers is used. Recommended size is  $B=H=D_n+50$  mm.

For  $B=H$  up to 400 mm minimal size is  $L=400$  mm.

For  $B=H$  over 400 mm minimal size is  $L=800$  mm (carried out by simmetrical additional pieces 2 x 200 mm).

On request we can make a damper with round reducers with connection flange.

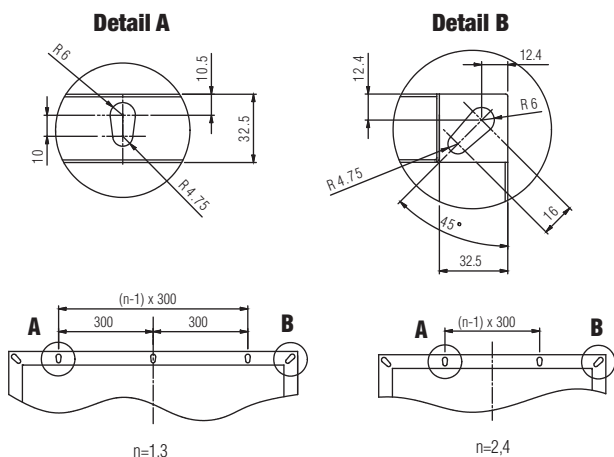

Connection flange geometry

**Connection flange geometry**

Flange is made as showed in the drawing, number of holes depends on dimension of individual sides.

dim. H or B (mm)	No. of holes n
up to 399	0
400 – 699	1
700 – 849	2
850 - 1339	3
> 1400	5

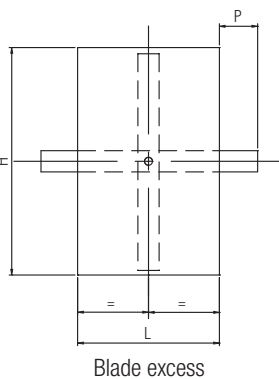

Blade excess

**Geometrical characteristics – accessories**

At installation there must be considered, that the blade in opened position can exceed the damper length.

Blade excess is  $P=(H-L)/2$ , and if the result is negative, the blade is inside of the housing. (Standard damper length  $L= 400$  mm).

A blade-related excess can obstruct installation of various connection elements such as spheres and additional meshes etc. In such cases an extension of the dampers can be provided by our company in the measurements  $B \times H$ , length from  $L_k=160$  to  $L_k=500$  mm.

An additional protection mesh can also be produced in the cases where the damper is cut off without being attached to a duct.

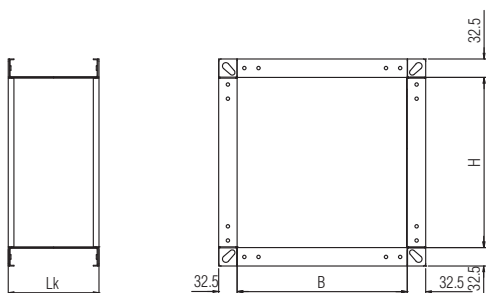

Additional piece

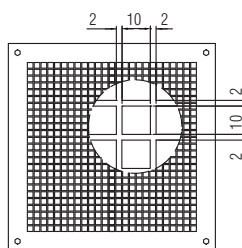

Protection mesh

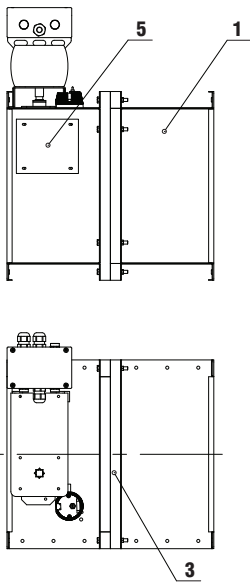

PL-15 Ex with E35 and E36

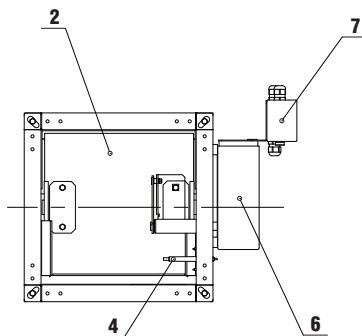

**Fire damper with electric actuator E35 or E36**

Characteristics:

- Classification ATEX, II 2G IIB Tx, zone 1 or 2
- Choice of electric actuator depends on the size of the damper
- Control E35 version with lower torque 5 Nm (for a limited dimension spectrum, see Table 1)
- Control E36 version with higher torque 15 Nm (no limitations about damper size)

**Component parts:**

1. Housing made of galvanised sheet steel
2. Blade made of special insulation material
3. Heat detachment of casing
4. Temperature trigger, melting point 72 °C
5. Control opening
6. Electric actuator on H side
7. Connection dose

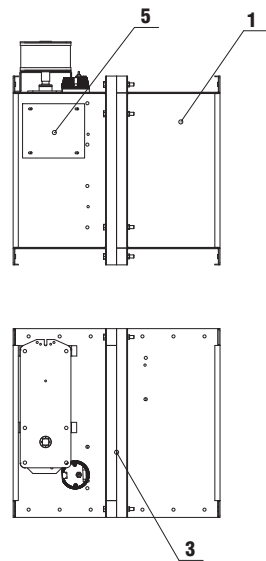

PL-15 Ex with E5 and E6

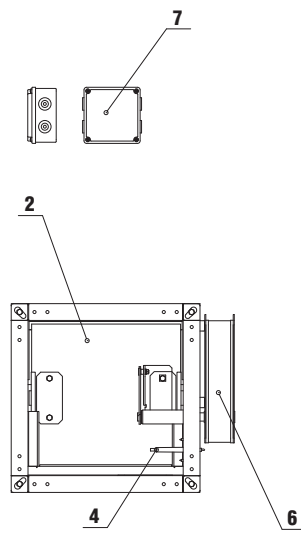

**Fire damper with electric actuator E5, E6, E15, E16**

Characteristics:

- Classification ATEX, II 2G IIB Tx, zone 1 or 2 (explosion unsafe zone only in the inside of the damper or duct - inside Ex):
- Choice of electric actuator depends on the size of the damper
- Control E5, E6, version with higher torque 12 Nm (no limitations about damper size)
- Control E15, E16, version with lower torque 4 Nm for a limited dimension spectrum, see Table 1)

**Component parts:**

1. Housing made of galvanised sheet steel
2. Blade made of special insulation material
3. Heat detachment of casing
4. Temperature trigger, melting point 72 °C
5. Control opening
6. Electric actuator on H side
7. Connection dose

Note: connection dose position depends od damper dimensions.

**Table1: Dimension of electric actuators E15, E16, E35 range**

B (mm)	H(mm)								
	150	200	250	300	350	400	450	500	550
150									
200									
250									
300									
350									
400									
450									
500									
550									
600									
650									
700									
750									
800									
850									
900									
950									
1000									

**Legend:**

- The range of applicability for E15, E16, E35 actuators
- The range of applicability for E15, E16, E35 actuators; fire dampers with reduced dimensions, B or H basis = min. 250mm

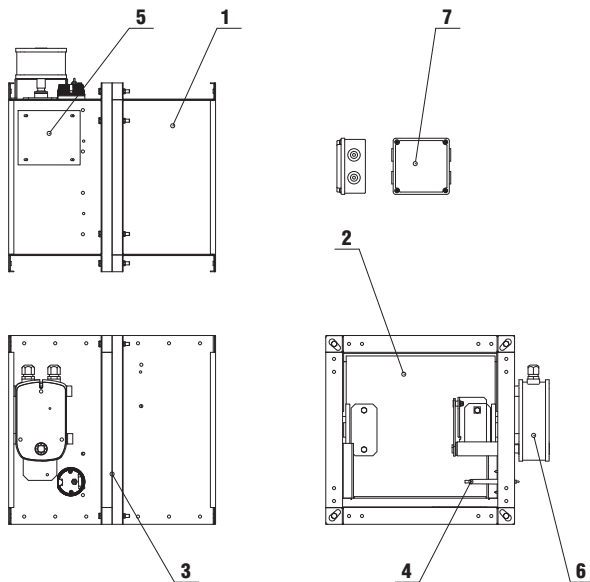

PL-15 Ex with E15 and E16

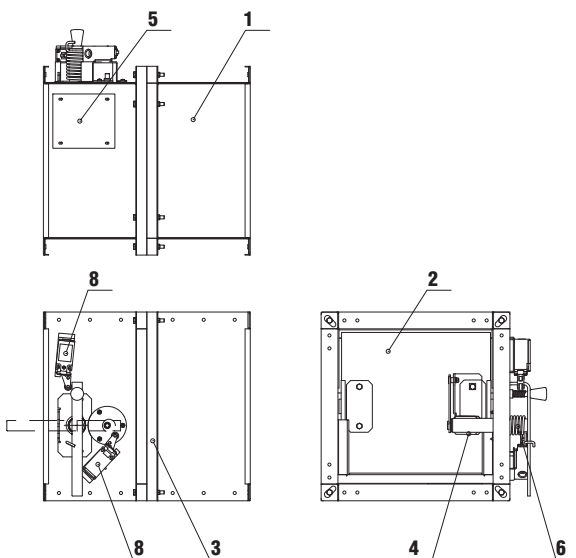

PL-15 Ex A2 version

**Fire dampers with manual handling – fusible link release A2**

**Characteristics:**

- Classification ATEX, II 2G IIB Tx, zone 1 or 2 (explosion unsafe zone only in the inside of the damper or duct - inside Ex);
- T12 – additional limit switches for opened – closed position
- Testing and replacing of thermal release link is possible only from the outside

**Component parts:**

1. Housing made of galvanised sheet steel
2. Blade made of special insulation material
3. Heat detachment of casing
4. Temperature trigger, melting point 72 °C
5. Control opening
6. Manual handling – fusible link release A2
8. End switch 2x

**Installation and technical data**

Installation and other technical data: see technical catalogue for PL-15 - classical version.

Ordering key:

**PL-15 E120S / A2 / T12 / Ex-Z B x H (\*)**

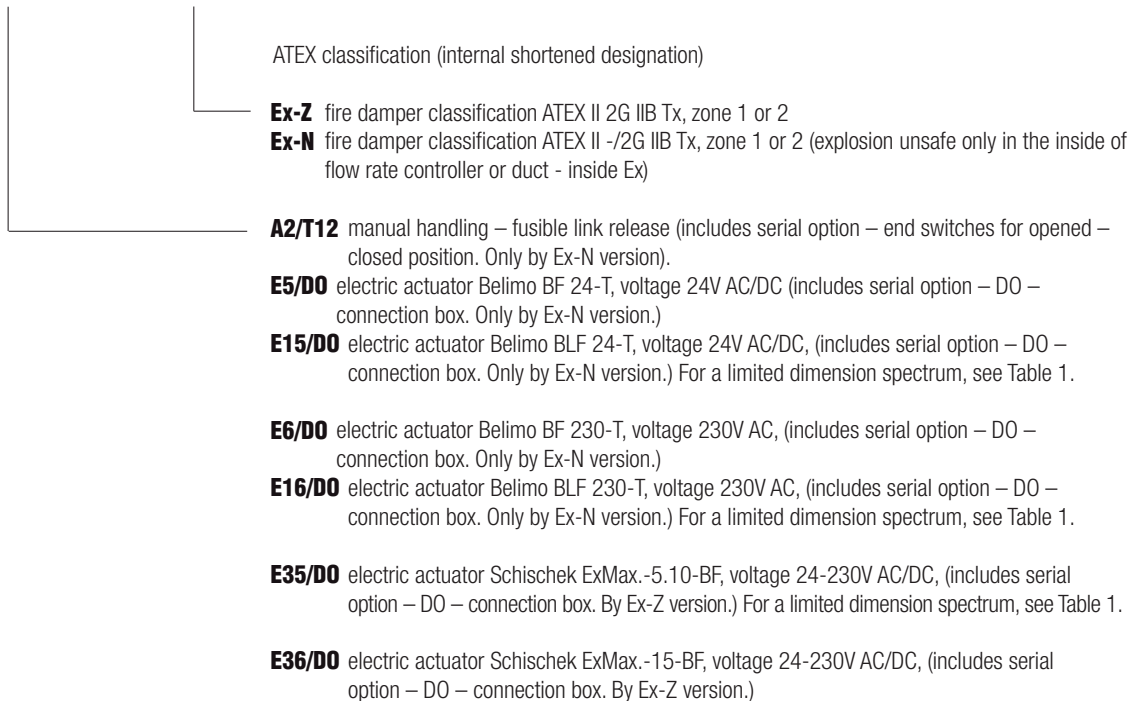

\*Non-standard measurement sizes

Note: All electromotor versions E... have an integrated limit switch for closed and open positions.

Controls E9 and E19 are also available for the Ex-N versions on request. See General catalogue.



### Application of air handling units Klimair2 in explosion proof version

Air handling units are devices that maintain explosion safety with the choice of appropriate materials for casings, parts and components as well as the selection of components and other equipment in explosion proof grade.

#### Air handling units in explosion proof grade can be constructed of the following elements:

- volume control dampers
- flexible connections
- droplet eliminator
- filters
- fan with drive
- steam humidifier
- heat exchanger
- recuperator
- sound attenuation splitters

All elements are produced in accordance with ATEX and have all the necessary certificates.

#### Product suitability:

- equipment group II
- equipment category 2 and 3
- explosive atmosphere, caused by gases, steam, fog G
- temperature class T3 (max. average temperature + 200 °C) and/or T4 (max. average temperature + 135 °C)
- protection based on the standard SIST EN 13463-1:2002 – basic methods and requirements

An air handling unit marked II 2 G suitable for operation in zones 1 and 2.

An air handling unit marked II 3 G is suitable for operation in zone 2.

**Example:** II 2 G; EEx IIB T4

**EEx** - means that the product is in accordance with one or more standards from the SIST EN 13463-1:2002 series: Non-electric equipment for potentially explosive atmospheres - basic methods and requirements.

**IIB** - explosion group

**T4** - temperature class / max. temperature

#### Obligatory data on air handling unit:

- Name and address of the company, CE Marking, indication of series or type, serial number, production year
- Specific explosion safety indication , followed by the group symbol and equipment category
- The equipment group II is followed by the letter “G” (explosive atmospheres caused by gases, fumes or aerosols) and/or the letter “D” (for explosive atmospheres caused by dust).

#### Groups and categories our equipment is suitable for:

Equipment intended for use in the areas above ground that is threatened by explosive atmospheres and is not intended for underground use in parts of mines or those parts of ground installations in areas of these mines where combustible dust of gas may occur is categorized as equipment group II.

#### Equipment categories that designate the required protection levels are:

**Category 2** encompassing all equipment that is designed in a manner compatible with the working parameters set by the manufacturer and maintaining a high level of protection. This equipment is intended for use in areas where explosive atmospheres occur from time to time and are caused by gas, fumes or aerosols with fluid or dust particles. Protection measures connected with this equipment in the category maintain the necessary level of protection, also in cases of frequent disturbances and errors on the equipment that must usually be taken into account.

**Category 3** encompasses equipment designed in such a manner that it is able to function in accordance with the working parameters set out by the manufacturer and maintain a normal level of protection. The equipment in this category is intended for use in areas where there is a small possibility of occurrence of explosive atmosphere caused by gas, fumes or aerosols with fluid or dust particles or this occurs very seldom and for shorter periods of time. The equipment in this category offers the necessary level of protection during normal operation. The equipment can be designed for specific explosive atmospheres. In that case they must also be appropriately marked.

**Definitions of hazard zones:**

According to the Rules on Anti-explosive Protection, all areas with potentially explosive atmospheres are divided into explosion hazard zones based on the frequency or likelihood of occurrence and duration of explosive atmospheres.

**Zone 1**

An area where, during normal operation, an explosive atmosphere temporarily occurs and is comprised of an air mixture and flammable substances in the shape of gas, fumes or liquid base aerosols.

**Zone 2**

An area where, during normal operation, an explosive atmosphere comprised of an air and flammable gas mixture, fumes or fog does not occur. If this however is the case, it occurs for a short period of time.

**Category 2:**

Documentation for this equipment must be prepared and saved by the institution responsible for certifications of conformity during the tests for conformity certification process for Ex equipment or Ex equipment maintenance. This documentation is used by the state authorities in the case of an explosion. The documentation cover must list the following information:

- The title “Dokumentacija za ne-električno Ex-opremo kategorije 2, ki je bila na voljo pred 1.7. 2003 (Documentation for non-electric Ex equipment category 2, available before 1 July 2003)”,
- Identification of equipment (e.g. name of equipment, type, factory number). risk assessment
- Data on explosion protection the equipment is suitable for (e.g. category (2G or 2D)), group of gases, temperature grade and
- The signature of the responsible individual.

**Category 3**

Documentation for the equipment must be prepared (see below). The list of this documentation is safeguarded by the conformity assessment body during the conformity assessment of installed Ex devices or Ex device maintenance. The documentation itself is safeguarded by the user of the equipment. This documentation is used by the state authorities in the case of an explosion. The documentation cover must list the following information:

- The title “Dokumentacija za ne-električno Ex-opremo kategorije 3, ki je bila na voljo pred 1.7. 2003 (Documentation for non-electric Ex equipment category 3, available before 1 July 2003),
- Identification of equipment (e.g. name of equipment, type, factory number). risk assessment
- Data on explosion protection the equipment is suitable for (e.g. category (3G or 3D)), group of gases, temperature grade and
- The signature of the responsible individual.



